

Diaphragm Pump 1420VDP DC

Flow	6,0 l/min
Final Pressure	1,9 bar
Final Vacuum	73 %

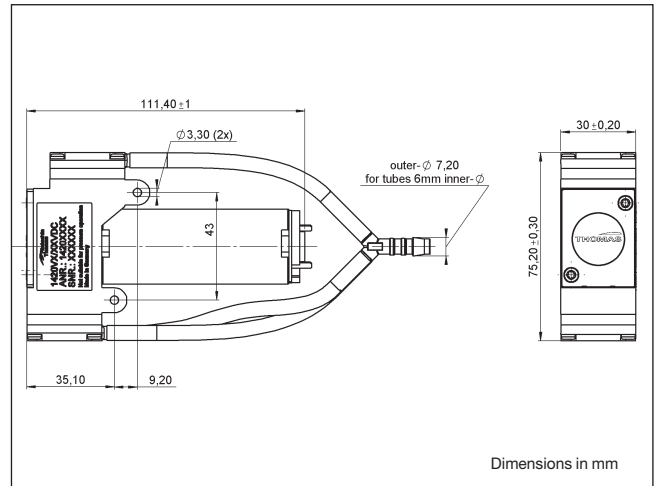

Pneumatic Data

Description	1420VDP/1,5/E/DC	
Part number	12 V	14200202
	24 V	14200203
Max. flow	6,0 l/min	
Max. intermittent pressure	1,9 bar	
Max. continuous pressure	0,7 bar	
Max. restart pressure	1,9 bar	
Max. intermittent vacuum	73%	
Max. continuous vacuum	73%	
Max. restart vacuum	73%	

Electrical Data

Motor type	DC brush ¹⁾
Nominal speed	3.200 rpm
Nominal voltage	12/24 V DC
Max. power consumption	7,9 W
Motor insulation class	E
Protection class	IP00

General Data

Ambient temperature	5 to 50°C
Media temperature	5 to 50°C
Weight	310 g
Configuration	Parallel

¹⁾ radio interference suppression according to EN 55011-B

Flow Curves

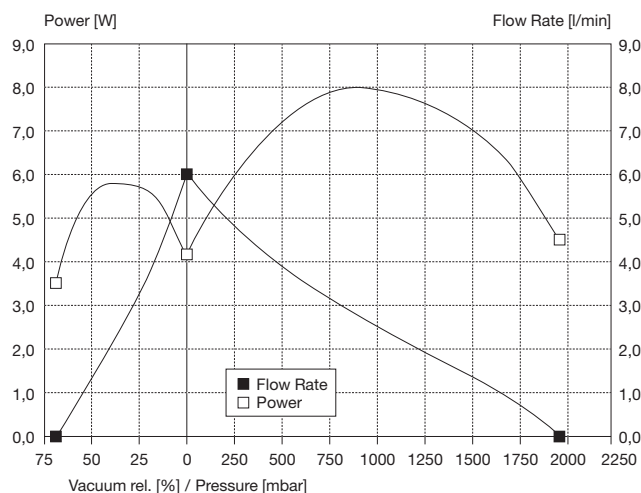

Wetted Parts

Pump head	PAA (IXEF)
Diaphragm	EPDM
Valves	EPDM
Tubing	PUR
Y-Connector	POM

Options

PPS (Ryton®)

Model key:

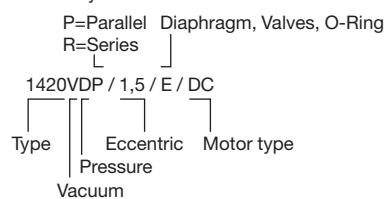

The information presented in this material is based on technical data and test results of nominal units. It is believed to be accurate and reliable and is offered as an aid to help in the selection of Thomas products. It is the responsibility of the user to determine the suitability of the product for the intended use and the user assumes all risk and liability whatsoever in connection therewith. Thomas does not warrant, guarantee or assume any obligation or liability in connection with this information.